

MCU-V5

Dimmer for constant voltage single color LEDs 12-24Vdc. Max 5A, RX 433,92MHz and 1 wired input

NEXTA
T E C H

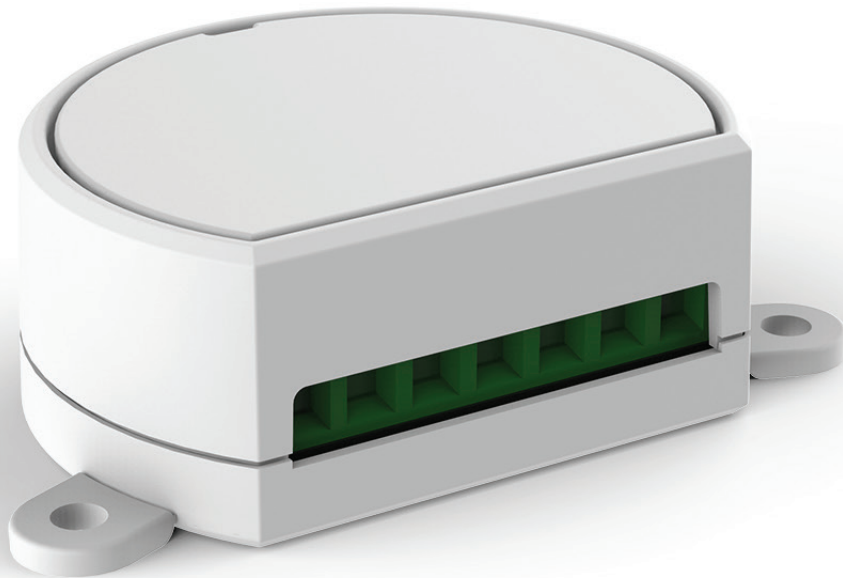

INDEX

1 - PRODUCT FEATURES

- 1.1 - TECHNICAL DATA
- 1.2 - DESCRIPTION

2 - ELECTRICAL CONNECTIONS

- 2.1 - CONNECTION DIAGRAM
- 2.2 - DESCRIPTION OF CONNECTIONS

3 - USE OF THE CONTROL UNIT

- 3.1 - USE VIA RADIO
- 3.2 - USE VIA WIRE

4 - CONTROL UNIT SETTINGS

- 4.1 - FADE SETTING: GRADUAL SWITCH ON
- 4.2 - FADE SETTING: GRADUAL SWITCH OFF
- 4.3 - SETTING ADJUSTABLE MINIMUM BRIGHTNESS
- 4.4 - "SAVE" FUNCTION (BRIGHTNESS LEVEL AT SWITCH-ON)
- 4.5 - TIMED ON
- 4.6 - LOAD STATE WHEN THE CONTROL UNIT IS SWITCHED ON
- 4.7 - FACTORY SETTING

5 - RADIO PROGRAMMING

6 - DELETION OF TRANSMITTERS

7 - FURTHER DETAILS

WARNINGS

- Installation must be carried out only by qualified technicians in compliance with the electrical and safety standards in force.
- All connections must be made with the power turned off.
- Use suitable cables.
- Do not cut through the aerial (see picture 1.1b)
- A suitably sized disconnection device must be set up on the electric power line that supplies the product.
- Disposal of waste materials must fully respect local standards.

1 - PRODUCT FEATURES

1.1 TECHNICAL DATA

Power supply	12-24 Vdc
Output	Max load 5A: 60 W (with 12Vdc) per output 120 W (with 24Vdc) per output
Type of load	Single colour LED with constant voltage
N° programmable transmitters	30
Radio frequency	433.920mhz ISM
Protection rating	IP20
Operating temperature	-20 +55 °C
Dimensions	52x43x21 mm

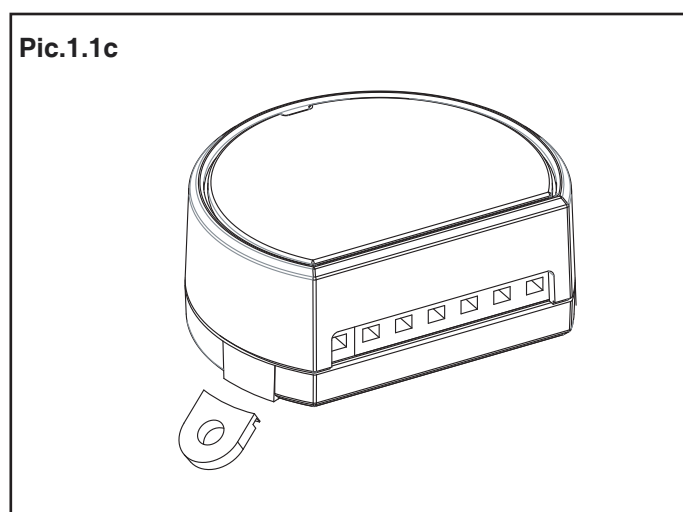
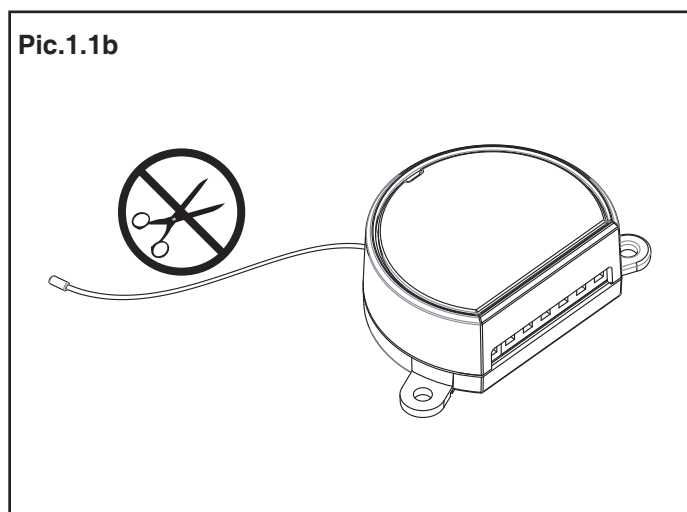
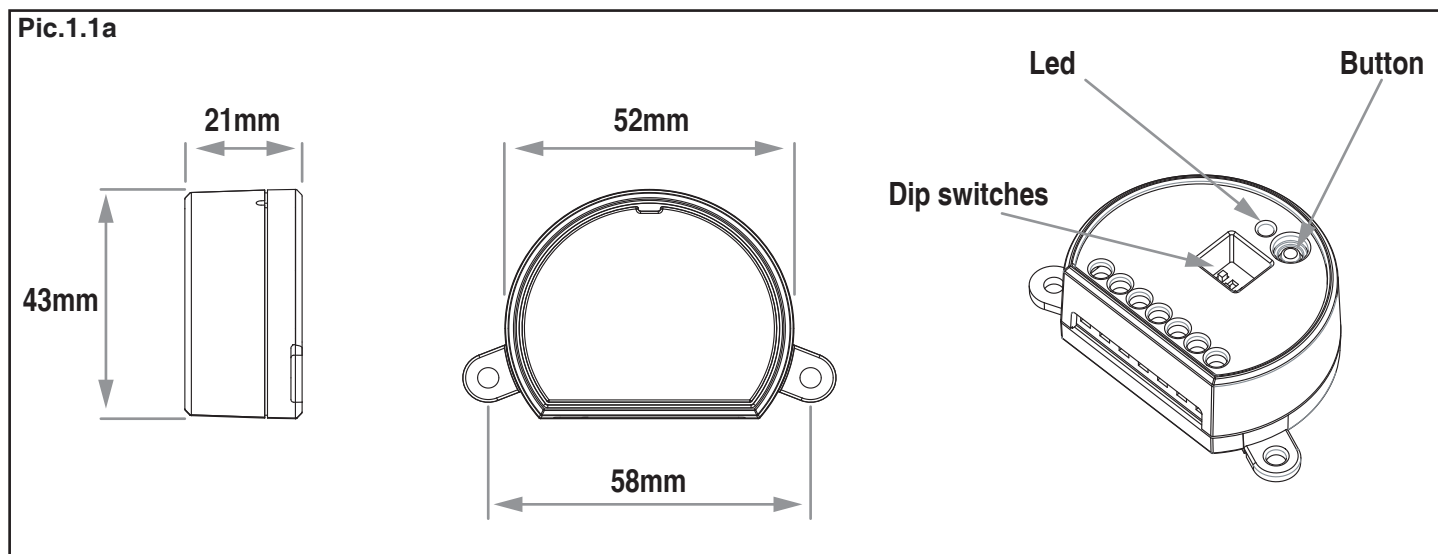

1.2 DESCRIPTION

This device is the miniature electronic control unit with dimmer function, for wireless and wired control of single colour constant voltage LEDs, power supply 12-24Vdc and maximum consumption of 5A.

One wired input, Wide-ranging and accurate dimmer function; fade on and off that can be set between 0 and 10 seconds.

The ISM (industrial, scientific and medical) radio frequency band guarantees a long range, even through walls and ceilings.

Simple programming with dip-switch, reduced dimensions with breakable tabs for fixing with screws or for insertion into interconnection boxes with 55 mm diameter.

Pic.1.2a

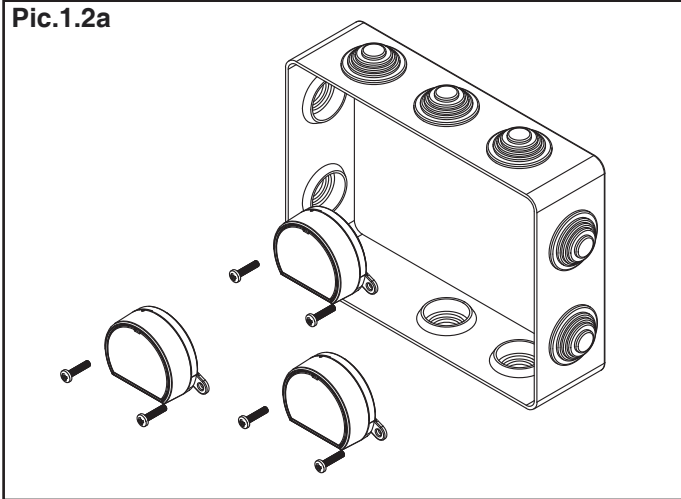

Pic.1.2b

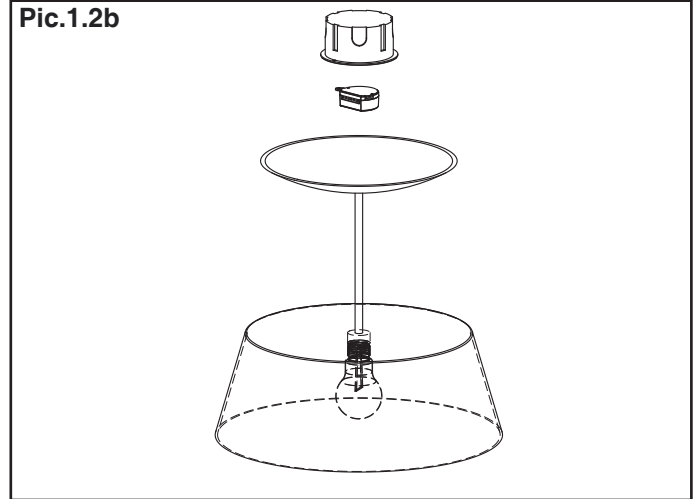

Pic.1.2c

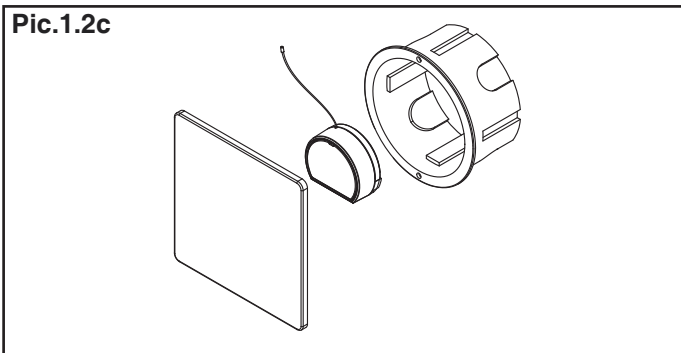

Pic.1.2d

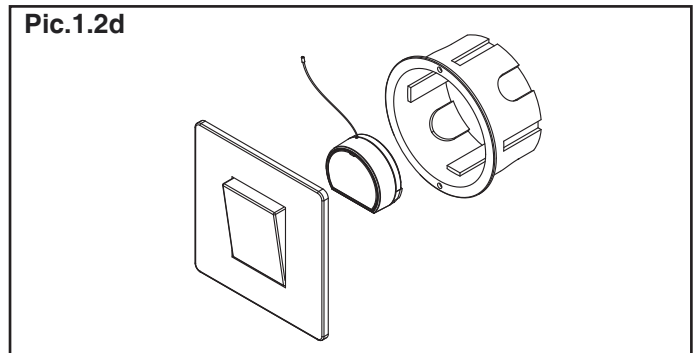

Pic.1.2e

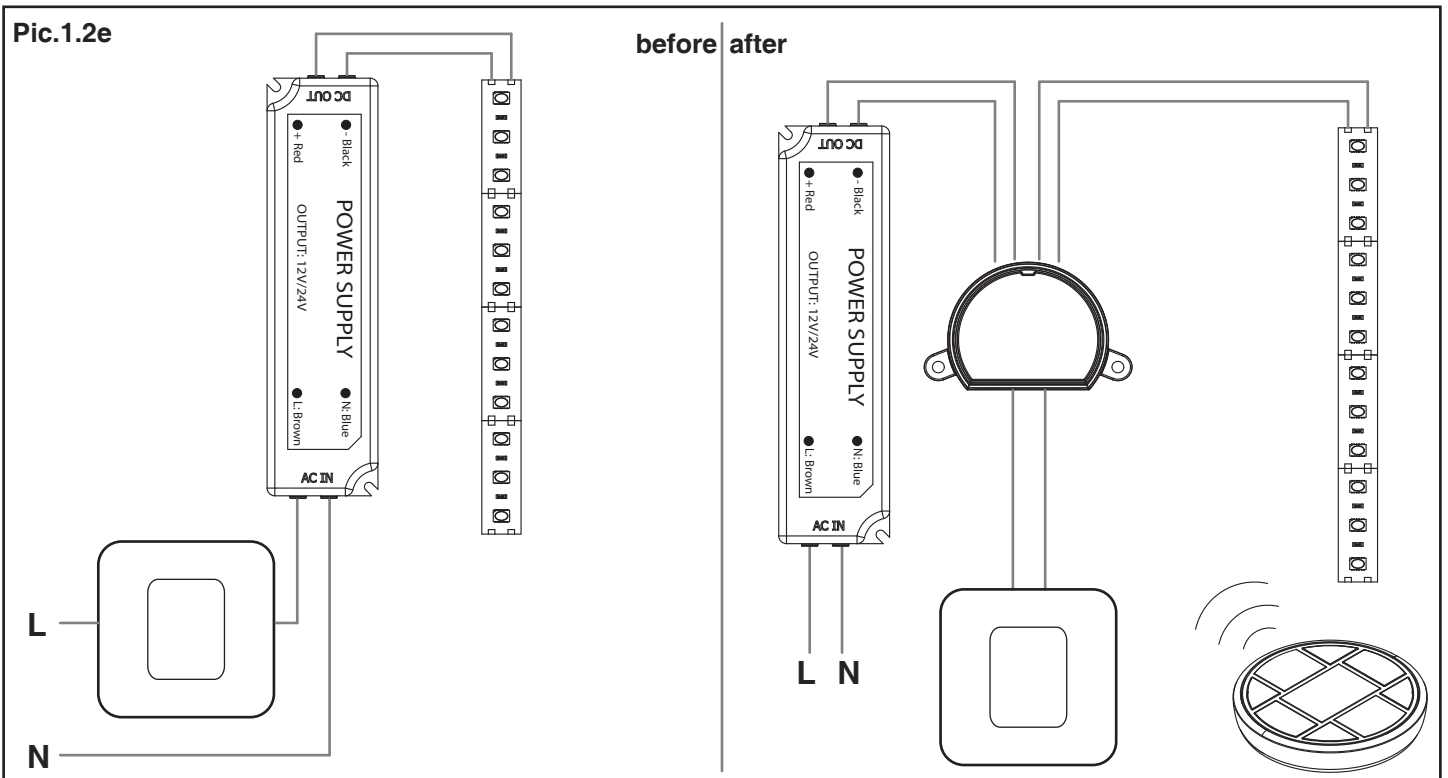

2.2 DESCRIPTION OF CONNECTIONS

- Use wires with a suitable cross-section for the load connected.
- Multiple buttons can be connected by using parallel cabling.
- Multiple buttons or loads can be connected by using parallel cabling.

TERMINAL	DESCRIPTION
1	Power supply -
2	Power supply + (12-24V)
3	Output +24V
4	Output -
5	Not used
6	Button P1 input
7	Common for button

3 USE OF THE CONTROL UNIT

3.1 USE VIA RADIO

To control the loads via radio you must have compatible transmitters and therefore must carry out the association procedure, see paragraph 5.

The transmitter's control modes depend on the transmitter model used.

If the transmitter is of a generic type, its operation depends on the way it is programmed (see paragraph 5, table 5.2a).

If the transmitter is multifunctional, refer to the transmitter manual, to the paragraph entitled "commands sent by the transmitter", bearing in mind that it is a "dimmer" device.

3.2 USE VIA WIRE

The device is set up to accept commands via wire by button in terminals 6 and 7.

Should you want to control the load

only via radio, it is not necessary to connect these devices for the control unit to work properly.

The behaviour of the key is shown in the following table:

	LOAD OFF	LOAD ON
INPUT P1: short press	On of load	Off of load
INPUT P1: long press	Dimmer intensity up of load	Dimmer intensity up / Dimmer intensity down of load

4 - CONTROL UNIT SETTINGS

4.1 FADE SETTING: GRADUAL SWITCH ON

Default: 0,5s

This procedure means you can set the duration of the switch-on time.

PROCEDURE:

STEP 1

Position DIPs 1, 2, 3 and 4 to ON-ON-OFF-ON.

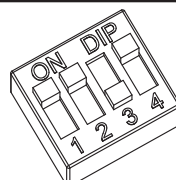

DIP 1, 2, 3, 4=
ON ON OFF ON

STEP 2

Press the button on the receiver for a short time.

The LED comes on and stays on.

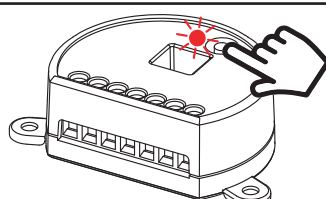

SHORT
PRESSURE

STEP 3

Press the button on the receiver for a short time count the number of flashes emitted by the LED:

FLASHES	SWITCH-ON TIME
1 flash	immediate ON
2 flashes	ON ~ 0,5s
3 flashes	ON ~ 2s
4 flashes	ON ~ 4s
5 flashes	ON ~ 10s

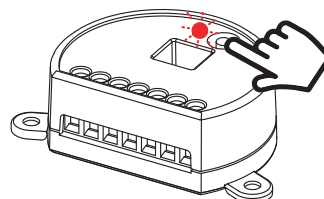

SHORT
PRESSURE

STEP 4

Press the button for a short time during the flash that corresponds to the function desired to end the count

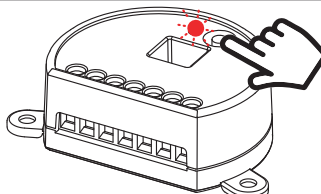

SHORT PRESSURE
DURING THE FLASH

4.2 FADE SETTING: GRADUAL SWITCH OFF

Default: 0,5s

This procedure means you can set the duration of the switch-off time.

PROCEDURE:

STEP 1
Position DIPs 1, 2, 3 and 4 to ON-OFF-OFF-ON.

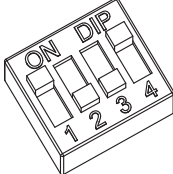

DIP 1, 2, 3, 4=
ON OFF OFF ON

STEP 2
Press the button on the receiver for a short time.
The LED comes on and stays on.

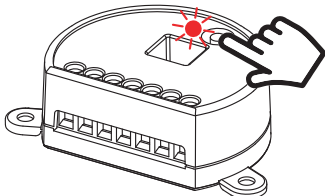

SHORT PRESSURE

STEP 3
Press the button on the receiver for a short time count the number of flashes emitted by the LED:

FLASHES	SWITCH-OFF TIME
1 flash	immediate OFF
2 flashes	OFF ~ 0,5s
3 flashes	OFF ~ 2s
4 flashes	OFF ~ 4s
5 flashes	OFF ~ 10s

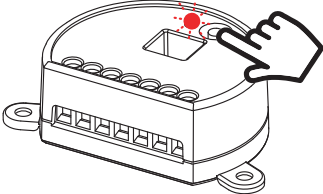

SHORT PRESSURE

STEP 4
Press the button for a short time during the flash that corresponds to the function desired to end the count

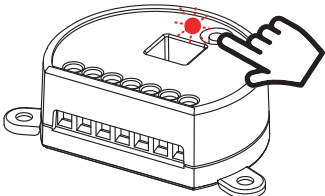

SHORT PRESSURE DURING THE FLASH

4.3 SETTING ADJUSTABLE MINIMUM BRIGHTNESS

This procedure allows you to set the minimum level of brightness at which it is possible to adjust the load.

PROCEDURE:

STEP 1
Position DIPs 1, 2, 3 and 4 to OFF-ON-OFF-OFF.

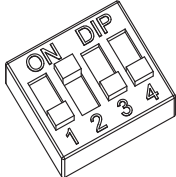

DIP 1, 2, 3, 4=
OFF ON OFF OFF

STEP 2
Press the button on the receiver for a short time.
The LED comes on and stays on.

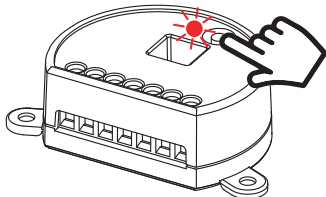

SHORT PRESSURE

STEP 3
Set the desired minimum brightness

STEP 4
Press the button on the receiver for a short time
The LED flashes 3 times to confirm.

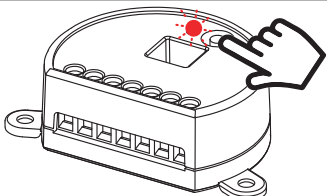

SHORT PRESSURE

4.4 "SAVE" FUNCTION (BRIGHTNESS LEVEL AT SWITCH-ON)

Default: save not on

PROCEDURE:

STEP 1

Position DIPs 1, 2, 3 and 4 to OFF-ON-OFF-ON.

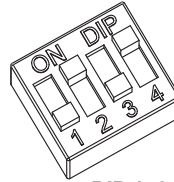

DIP 1, 2, 3, 4=
OFF ON OFF ON

STEP 2

Press the button on the receiver for a short time.

The LED comes on and stays on.

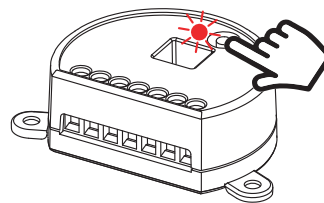

SHORT
PRESSURE

STEP 3

Press the button on the receiver for a short time.

Count the number of flashes emitted by the LED:

3 flashes= Last value set

6 flashes= Maximum brightness

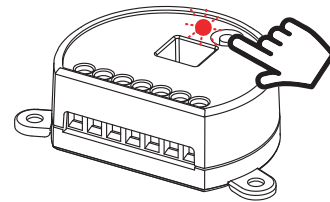

SHORT
PRESSURE

NUMBER OF FLASH	INTENSITY AT SWITCH-ON
3	Last value set
6	Maximum brightness

STEP 4

To change the setting, repeat the procedure from point 1; the control unit will alternate between 3 and 6 flashes.

4.5 TIMED ON

Default: No timing

This process is used to set the time for which the Leds stays on before an automatic switch off.

PROCEDURE:

STEP 1

Position DIPs 1, 2, 3 and 4 to OFF-OFF-OFF-ON.

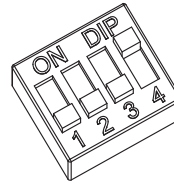

DIP 1, 2, 3, 4=
OFF OFF OFF ON

STEP 2

Press the button on the receiver for a short time.

The LED comes on and stays on.

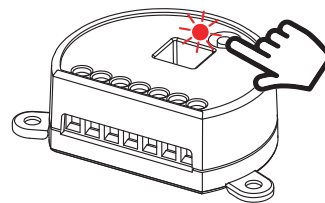

SHORT
PRESSURE

STEP 3

Press the button on the receiver for a short time count the number of flashes emitted by the LED:

FLASHES	TIMED ON
1 flash	No timing
2 flashes	1 minute
3 flashes	5 minute
4 flashes	15 minute
5 flashes	40 minute
6 flashes	1 hour
7 flashes	2 hours
8 flashes	3 hours
9 flashes	8 hours

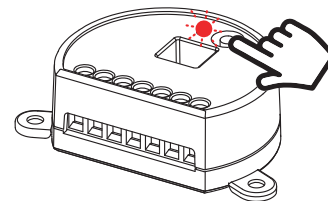

SHORT
PRESSURE

STEP 4

Press the button for a short time during the flash that corresponds to the function desired to end the count

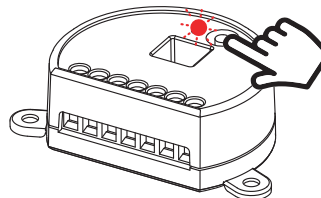

SHORT PRESSURE
DURING THE FLASH

4.6 LOAD STATE WHEN THE CONTROL UNIT IS SWITCHED ON

Default: Light Off

This process is used to set the state of Leds when the control unit is switched on (for example when the power supply is provided by a general switch or timer).

WARNING: the setting value can be "light off" in order to set the default.

PROCEDURE:

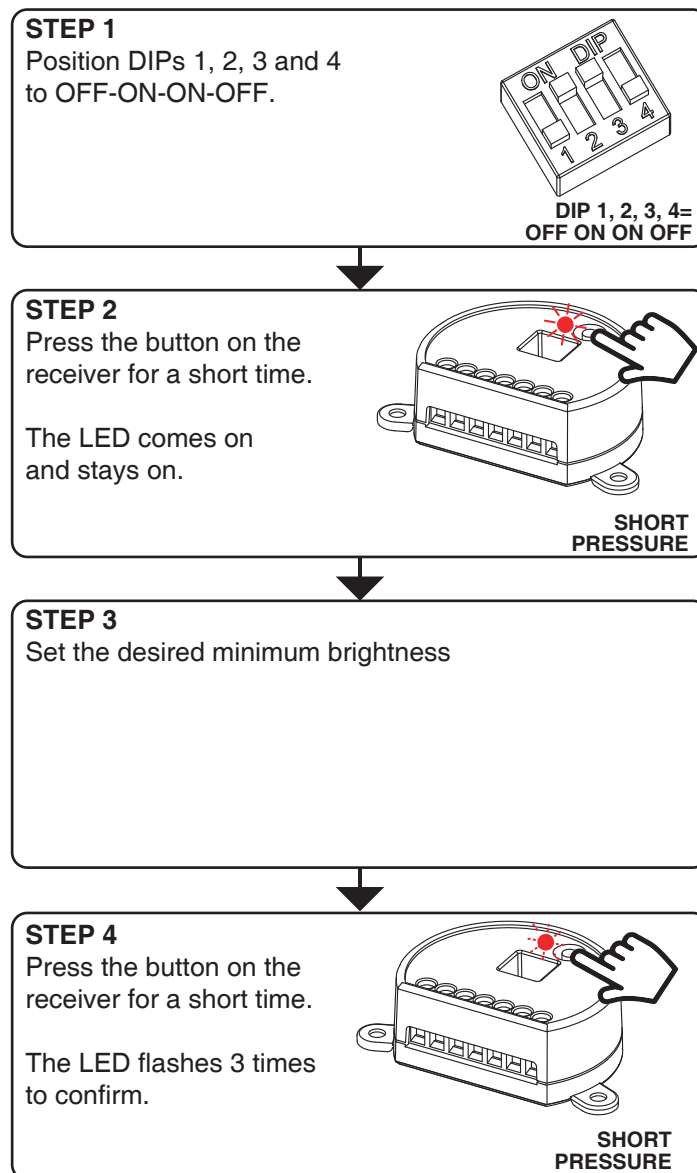

4.7 FACTORY SETTING

This procedure let you take the control unit back to factory settings.

FULL RESET OF THE CONTROL UNIT:

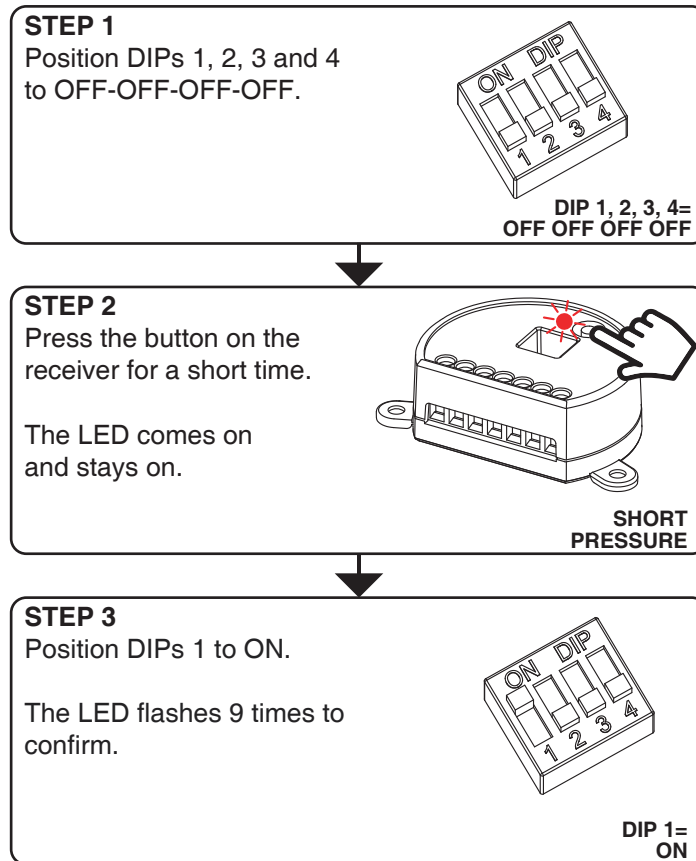

RESET PARAMETERS (NO DELETION OF RADIO MEMORY):

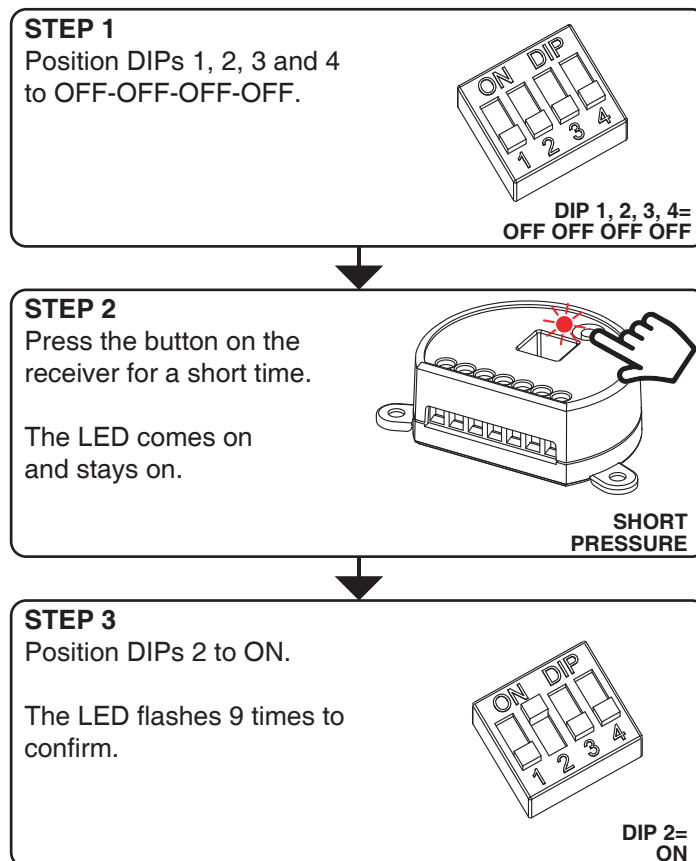

5 - RADIO PROGRAMMING

This procedure lets you programme compatible multifunctional or generic transmitters.

WHICH REMOTE CONTROL DO YOU WANT TO ASSOCIATE WITH THE CONTROL UNIT?

MULTIFUNCTIONAL TRANSMITTERS - MODELS AND CODES



CODE:
HB70-1L



CODE:
HB80-30D,
HB80-2L,
HB80-4L,
HB80-4RGBW,
HB80-30RGBW

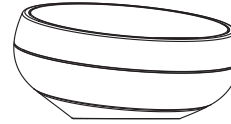

CODE:
HB90-6DM
HB90-8P



CODE:
TOUCH-1L
TOUCH-1 DIM

With multifunctional transmitters the transmitter control modes depend on the model used. Refer to the transmitter manual, to the paragraph entitled "commands sent by the transmitter", bearing in mind that it is an "dimmer" device.

GENERIC TRANSMITTERS - MODELS AND CODES



CODE:
HB70-5G

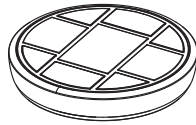

CODE:
HB80-6G

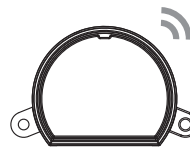







CODE:
MCU-TX4



CODE:
TOUCH-1G
TOUCH-2G
TOUCH-4G

With generic transmitters, the transmitter's control modes depend on the function associated with the key during the association procedure. The available function for the key are:

TABLE 5.1 KEY FUNCTIONS OF THE GENERIC TRANSMITTER

POSITION OF DIP IN "STEP 1b" OF THE PROCEDURE	KEY FUNCTION	POSITION OF DIP IN "STEP 1b" OF THE PROCEDURE	KEY FUNCTION
 DIP: ON ON ON OFF	ON / OFF	 DIP: OFF OFF ON OFF	Short pressure= ON Long pressure= DIMMER UP
 DIP: OFF ON ON ON	Short pressure= ON / OFF Long pressure= DIMMER UP / DIMMER DOWN	 DIP: ON ON OFF OFF	Short pressure= OFF Long pressure= DIMMER DOWN
 DIP: OFF OFF ON ON	OFF	 DIP: ON OFF OFF OFF	Soft Off 1h: fade off in 1h. (see paragraph 7.1)
 DIP: ON OFF ON ON	ON		

PROCEDURE

WHICH TRANSMITTER DO YOU WANT TO PROGRAMME?

MULTIFUNCTION TRANSMITTER
(see models and codes on previous page)

GENERIC TRANSMITTER
(see models and codes on previous page)

STEP 1a
Position DIPs 1, 2, 3 and 4 to ON-ON-ON-ON

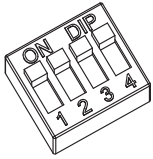

DIP 1, 2, 3 e 4= ON ON ON ON

STEP 1b
Positions DIPs 1, 2, 3 and 4 according to the function you want to associate with the remote control key.
See table 5.1 on the previous page.

STEP 2
Press the button on the receiver for a short time.
The LED comes on and stays on.



SHORT PRESSURE

STEP 3
Make a transmission with the transmitter to be saved (see transmitter manual, paragraph entitled "transmitter programming").
The LED on the receiver flashes 3 times to signal that it has been received.

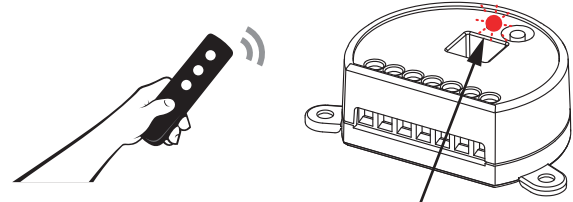

MAKE A TRANSMISSION WITH THE TRANSMITTER **THE LED FLASHES 3 TIMES**

STEP 4
The control unit listens for 30 seconds in case you want to add other transmitters.
To immediately exit the procedure give a short pressure on the button on the receiver.
The LED turns off

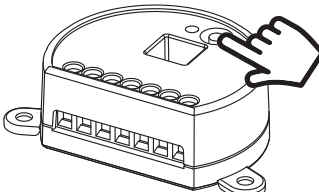

SHORT PRESSURE

6 - DELETION OF TRANSMITTERS

These procedures let you delete from the memory transmitters that have already been programmed.

6.1 DELETION OF SINGLE TRANSMITTER

STEP 1

Hold the receiver button down for 8 seconds.

The LED begins to flash

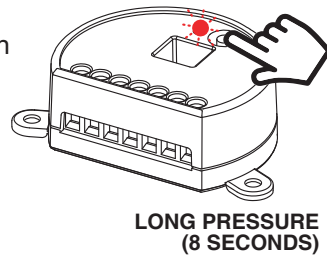

STEP 2

Make a transmission with the transmitter that you want to delete.

The LED flashes quickly and turns off.



MAKE A TRANSMISSION
WITH THE TRANSMITTER

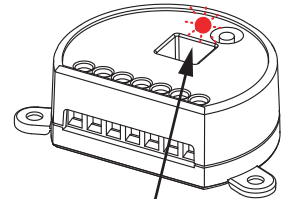

LED FLASHES QUICKLY

6.2 DELETION OF ALL THE SAVED TRANSMITTERS

STEP 1

Hold the receiver button down for 8 seconds.

The LED begins to flash

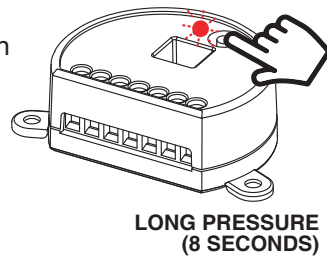

STEP 2

Press the button on the receiver for a short time.

The LED starts flashing quickly and turns off.

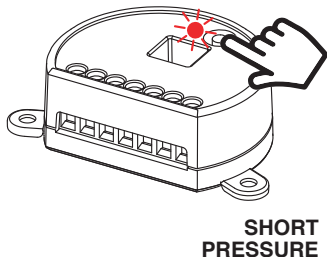

7 FURTHER DETAILS

The following paragraphs describe the ways the lights connected are commanded and controlled.

7.1 "SOFT OFF 1 HR" FUNCTION: FADE OFF

The "Soft off 1 hr" function is a gradual fading off in one hour starting from the colour and intensity set at the time the command was sent.

This function can be activated after adjusting the colour and intensity as desired (via radio or wire):

- VIA RADIO WITH GENERIC TRANSMITTER: with a generic transmitter programmed with the "soft off 1 hr" function.

This gradual switch-off can be interrupted at any time by the sending of another command via radio or via wire.



MNLMCUV5ENV1.0

Nexta Tech

company brand of Team srl
via G.Oberdan 90, 33074
Fontanafredda (PN) - Italy
Ph. +39 0434 998682
Email: info@nexta-tech.com
Web: www.nexta-tech.com